

# LED Lamp Wall Sconce

**EW0508**  
INSTALLATION SHEET

## START FROM HERE

- Make sure power is completely off at the fuse box.
- Have your fixture installed by a qualified licensed electrician
- Prepare everything in a clear area.
- Wear gloves at all times during this installation.
- Read instructions carefully before you start assembly.
- Keep this instruction sheet for future reference.

**Technical Support:** 1-877-452-6858

### Please Note:

- All Kuzco LED fixtures come with pre-wired LED module(s).
- Unless instructed to do so, please do not touch any part of the LED module(s) as any unnecessary contact with the module could cause permanent damage.
- For dimming, an ELV (Electronic Low Voltage) type of dimmer is required.

**1.** Remove the fixture from its original packaging. Remove the mounting plate (**2b**) from within the canopy backplate (**1c**) and attach it to the electrical junction box (**2d**), using the screws (**1d**) provided in the hardware package.

**2.** Attach the canopy backplate to the mounting plate, which is attached to the electrical junction box on the wall. First attach all wiring (**2c**) with the provided marrets (white to white "N", black to black "L", ground to ground "G"). Now push the canopy backplate (**1c**) onto the mounting plate (**2b**) allow the screws (**2a**) to pass through the backplate holes (**1c**). Next, thread the nuts (**1b**) onto the screws (**2a**) this will secure the fixture to the wall.

**3.** To prevent moisture from entering the outlet box and causing a short, seal around the top and side perimeter between the fixture and the wall surface with weather resistant caulking (see illustration 3). The space at bottom should be left un-caulked to prevent moisture build-up. Apply a small amount of weather resistant caulking around the side perimeter between the cap nut and mounting plate.

**4.** You have now completed the installation of your fixture, please enjoy.

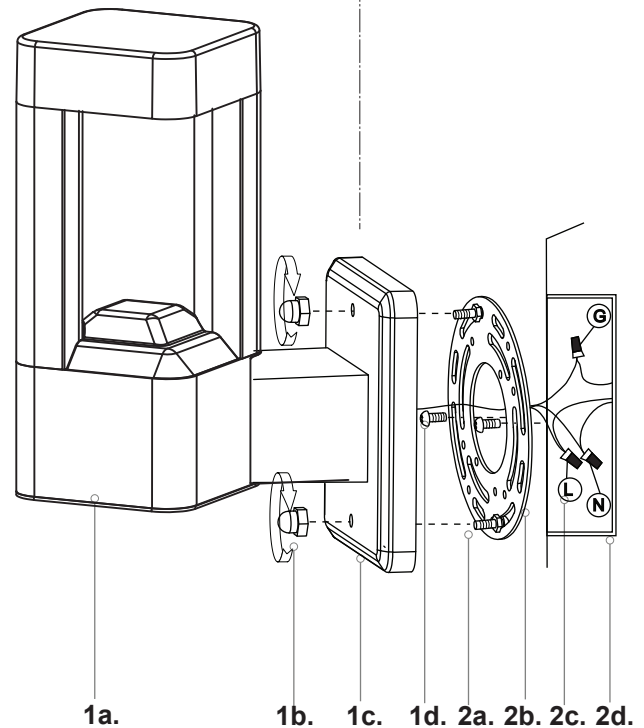
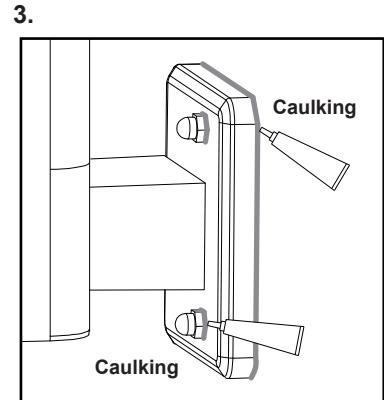

**KUZCO**  
LIGHTING

19054 28th Avenue Surrey, BC Canada V3S 6M3  
T: 604 538 7162 TF: 1-855 85 KUZCO F: 604 538 7196  
W: kuzcolighting.com  
20160527